



Settlement measurements at structures are taken either with extensometers for relatively small displacements (see Section 2.4) or with settlement gauges for relatively large displacements.

The simplest version of our settlement gauge consists of a steel pipe dia. 50 mm, which has a hemispherical stainless steel knob fitted at its top end (see Fig. 1).

A second version consists of a sleeve-coupled aluminium or plastic tube with magnetic rings of 72 mm outer diameter fastened to the outside at random intervals. These rings move according to how the foundation settles. The change in position of the various magnetic fields is measured via a reed contact with a measuring probe inserted in the gauge. Measuring accuracy equals  $\pm 2$  mm.

For dam fills the gauge can be extended to comply with the fill, otherwise the gauge is inserted in a bore hole. To increase the measuring accuracy on fills, an aluminium settling plate can be fitted over the magnetic rings.

When ordering, please specify:

- Single-point gauge made of steel
- Plastic gauge or aluminium gauge
- Number of magnetic rings
- Size of settling plates, if required
- Length of probe cable

We wish to point out that tubings with an inner diameter of 50 mm are used in the installation of our guide tubes made of aluminium or plastic and that these tubings are also suitable for taking tilt measurements with the inclinometer.

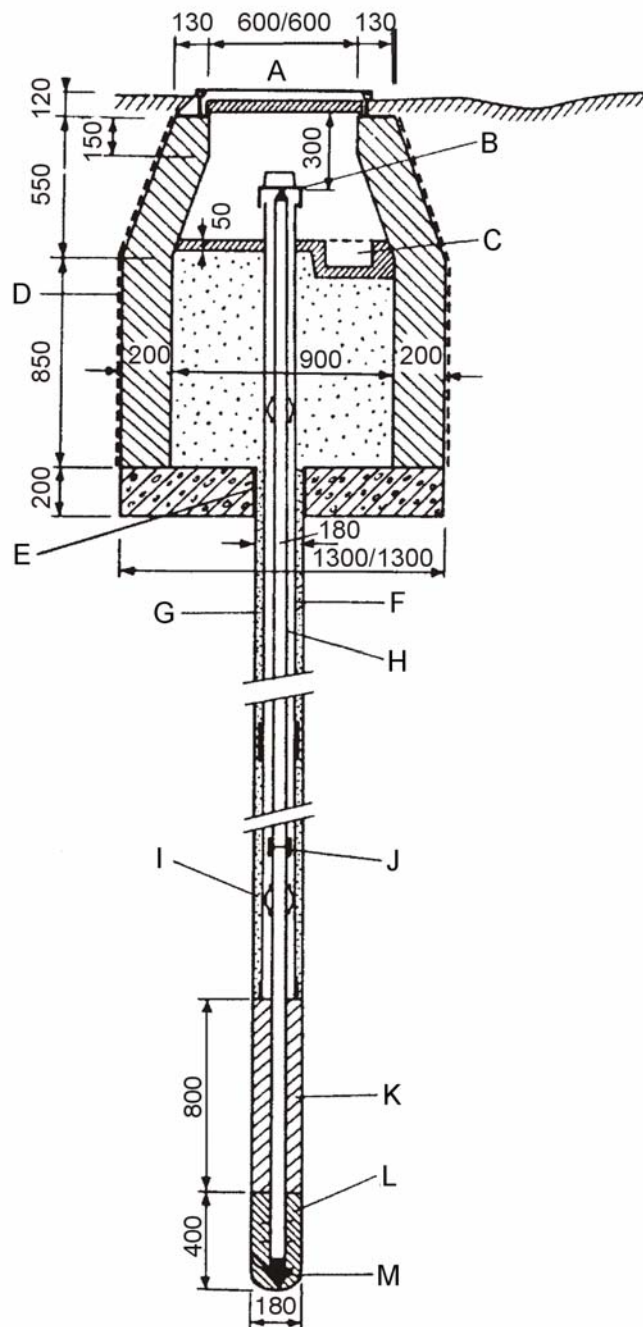

Fig. 1 Settlement gauge or contractometer (dimensions in mm)

- |   |                      |   |                                    |
|---|----------------------|---|------------------------------------|
| A | Cover                | B | Hemispherical stainless steel knob |
| C | Drainage             | D | Asphalt coating                    |
| E | Insulation           | F | Casing                             |
| G | Sand                 | H | Pipe                               |
| I | Distanzringe à 3-5 m | J | Coupling for extensions            |
| K | Clay                 | L | Expansive grout                    |
| M | Plug end of pipe     |   |                                    |

**Sales Information**

- 2.5.1 HDPE casing (25 x 2)
- 2.5.2 Pipe (3/8), steel,  
in lengths à 3 m incl. sleeve
- 2.5.3 Cast tip for pipe
- 2.5.4 Head for pipe  
assigned as benchmark